

- Drum motor with torque monitor
- 15 speed levels between 8 and 140 rpm
- Control unit mounted on discharge sheet
- Electrical connection 230V/50Hz
- Easiest operation
- Wiper above the screw
- Brackets to attach to conveyor

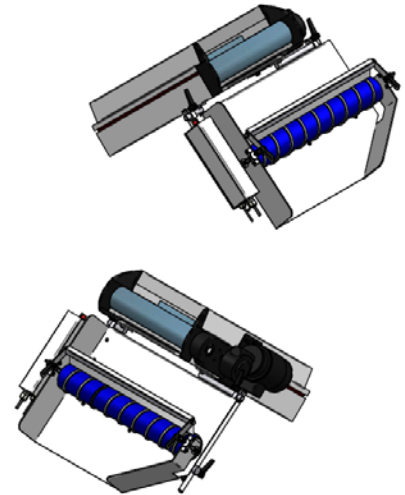
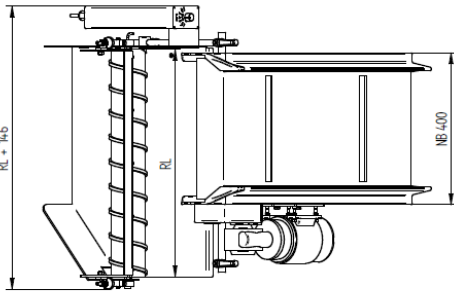

Typ	Rollenlänge RL mm	Nennbreite NB mm
SAL 600	600	200
SAL 600	600	300
SAL 600	600	400
SAL 800	800	500
SAL 800	800	600

SPECIFICATION*

Samples available	
Cycle Time (s)	
No. of parts per shot (pcs.)	
No. of runners per shot (pcs.)	

Type (Discharge in conveying direction SAL: left / SAR: right)	<input type="checkbox"/>
Separation length	
Screw Material (Standard: PVC, other materials available at extra charge)	
Discharge sheet material (Standard: Aluminium, other materials available at extra charge)	
Screw height	

Notes / Special requirements

* further options available on request